

### WIND TURBINE HYDRAULIC SYSTEM SINGLE STATION



#### DESCRIPTION

The MF100S-WTS Wind Turbine Hydraulic System simulator has the same superb capability as the MF100S simulators for teaching a complete course in Practical (Basic) Hydraulics. However, an extensive component package has been added to increase their capability to include a comprehensive course in wind turbine hydraulic systems and troubleshooting hydraulic components using leakage path analysis methods.

The Wind Turbine industry needs skilled maintenance professionals who are trained in all aspects of state-of-the-art wind turbines, which includes, among other things, hydraulics.

The MF100S-WTS hydraulic training simulator is designed to teach students vital aspects of wind turbine technology with respect to hydraulics:

- Hydraulic safety
- How to read and understand hydraulic schematics
- Hydraulic principles and laws
- Hydraulic component theory of operation
- Electro-hydraulics
- Proactive maintenance
- Diagnostics

The extremely versatile MF100S-WTS incorporates everything an instructor needs to teach all of the above because it has the identical hydraulic components found on a hydraulically-controlled wind turbine:

- Electro-hydraulic blade pitch control system
- Brake system

Both the hydraulic and electronic systems are based on a “build-and-drive” platform. Wind turbine diagnostics **MUST** be executed with utmost precision to avoid safety hazards unique to wind turbines – especially unnecessary trips navigating immense towers.

The MF100S-WTS features pressure/leak testing – a technique for testing hydraulic components that is so unique that over 95% of the components on a wind turbine can be diagnosed with the unit safely locked out. Pressure/leak testing can be done without removing a component from the system or disassembling a component. All the hydraulic components on the MF100S-WTS can be faulted at the flick of a switch. The fault is absolutely identical to a fault a trained technician will experience on-the-job. Included in the price of the MF100S-WTS:

1. State-of-the-art wind turbine hydraulic training simulator, single station
2. Student workbook covering:
  - Hydraulic safety
  - Basic hydraulic laws and principles
  - Complete guide to ANSI and ISO symbols
  - Hydraulic component theory of operation (continued on back)
  - Simulator activities including complete wind turbine hydraulic system set-up and diagnostics
  - Accumulator charging kit so students can learn how to safely and correctly service and maintain accumulators
  - Instructor workbook

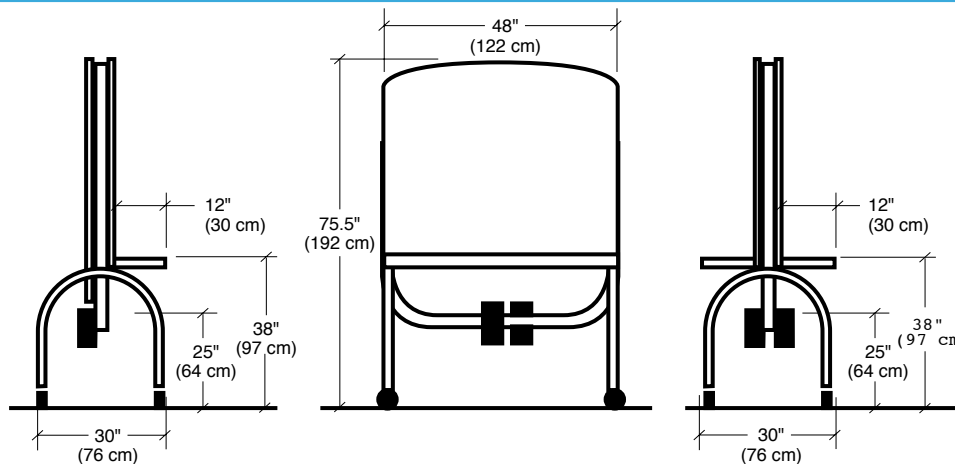

### Shipping Specifications:

Shipping weight: 850 lbs (386 kg)  
 Shipping dimensions: 75.5" tall x 48" wide x 30" deep  
 (192 cm x 122 cm x 76 cm)

### Warranty:

FPTI™ warrants its products against defect in materials or workmanship for a period of two years from date of delivery.