

DESCRIPTION

The ideal setting for teaching and learning hydraulics would be to set up a classroom in a manufacturing facility for a few weeks where students study industrial hydraulics, and then move the classroom to a construction site for a few weeks where they could study mobile hydraulics.

For a student to gain maximum comprehension of hydraulics, he/she **MUST** learn in an environment wherein the theory is well presented, and the lab activities are executed on a variety of hydraulic systems, which are capable of operating through complete “load-cycles.”

FPTI™ created this exemplary learning environment - the MF100S-PH series hydraulic training simulator!

What sets the MF100S-PH hydraulic training simulator apart from all other simulators, is its unique ability to replicate a fully functional industrial or mobile hydraulic system, which is capable of operating with or without load.

The model MF100S-PH has four (4) directional control valves – two (2) are handlelever-operated, and two (2) are solenoid-operated. Students can construct systems with complexity equal to, and in many cases greater than, those found in typical industrial and mobile machinery.

In addition, the MF100S-PH simulator achieves yet another remarkable milestone in simulator design; a single simulator has the onboard capability to operate in fixed or variable displacement, pressure-compensated, and pressure and flow (load-sensing*) pump environments (**optional*).

Add the numerous additional unique features, and you’ll quickly discover that the MF100S-PH simulator is the most advanced in the world for both teaching and learning hydraulics.



The MF100S-PH simulator is equipped with the following standard components:

- All-steel, uniframe design with tubular construction;
- All non-flexible transmission lines made from stainless steel tubing with Swageloktype connections;
- All steel parts finished in high-quality powder coating;
- Four-wheel, heavy-duty casters with wheel locks;
- 2.5 Gallon (9.5 L) hydraulic reservoir integrated in frame;
- 1HP, 120V, single-phase, electric motor – operates on a single 20-amp circuit;
- Variable-displacement pressure-compensated, axial piston-type pump — adjustable from 1 GPM to 3.0 GPM (3.79 - 11.36 Lpm), and adjustable pressure from 200 PSI to 1000 PSI (13.8 - 69 bar);
- Pressure Control Valves:
 - a) Direct-operated pressure relief valve,
 - b) Pilot-operated pressure relief valve with remote option,
 - c) Sequence valve,
 - d) Counterbalance valve,
 - e) Pressure reducing valve;
- Directional Control Valves:
 - a) 3-position, 4-way, open-center, handlever-operated directional control valve,
 - b) 3-position, 4-way, tandem-center, solenoid-operated directional control valve,
 - d) 3-position, 4-way, closed-center, solenoid-operated directional control valve,
 - e) 3-position, 4-way, float-center, handlever-operated directional control valve;
- Flow Control Valves and Flow Dividers:
 - a) Needle valve,
 - b) Flow control valve,
 - c) Restrictor-type pressure-compensated flow control valve;
- Check valves:
 - a) Conventional in-line,
 - b) Pilot-operated (pilot-to-open),
 - c) Shuttle valve (with load-sense option only);
- Actuators:
 - a) Bi-directional hydraulic motor,
 - b) Double-acting, single-rod cylinder,
 - c) Double-acting, double-rod cylinder;
- Hydraulic hoses with quick-disconnect fittings:
 - a) Six (6) 24” hoses - Twelve (12) 40” hoses,
 - b) Two (2) hose connectors - to extend hose length;
- Six (6) “T” assemblies
- Two (2) in-line flow meters
- Three (3) Glycerine-filled, Bourdon tube pressure gauges (0 – 1000 PSI)

- Digital tachometer;
- Digital oil temperature gauge;
- Digital ambient temperature gauge;
- Electronic stopwatch with auto retract;
- Ammeter;
- Return-line, spin-on/off filter with by-pass indicator;
- Oil level sight glass;
- Oil reservoir filler/breather located in drip tray to prevent spilling;
- Integrated load with hand-lock load engagement mechanism;
- Illuminated load select and de-select switch;
- Motor on/off switch with thermal protection;
- Two (2) joystick controllers for solenoid-operated directional control valves;
- All moveable parts are covered with transparent protective covers;
- Two (2) lined work trays are located on motor housing to hold diagnostic instruments and tools for pump set-up, adjust, and test (if applicable);
- Integrated, swing-out paper towel holder;
- Swing-out/stow-away hose caddy, which holds all hydraulic hoses and “T’s” neatly. Quick-disconnects are conveniently held in upright position to prevent oil leakage;
- Front panel is fabricated out of 3/16” brushed aluminum. All components are clearly marked with their respective symbols silkscreened onto the aluminum panel for a lifetime finish; and,
- Valve Docking Plate (VDP) allows the addition of numerous optional valves to be used on the simulator.

The following items are also included with the model MF100S-PH Practical Hydraulics Simulator:

1. Full-color PowerPoint® presentations in CD format;
2. Student workbooks featuring simulator activities; and,
3. Instructor's manual.

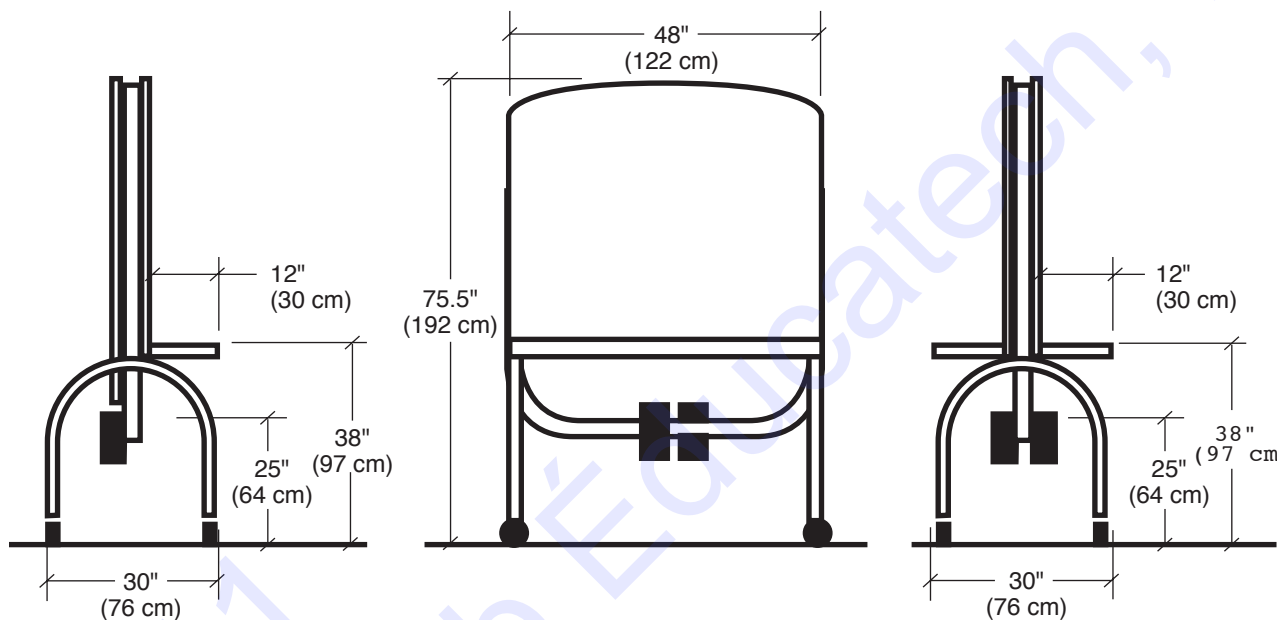

SHIPPING SPECIFICATIONS

Weight: 750 lbs (338 kg)

Dimensions: 75.5" tall x 48" wide x 30" deep (192 cm x 122 cm x 76 cm)

WARRANTY

FPTI™ warrants its products against defect in materials or workmanship for a period of two years from date of delivery.